

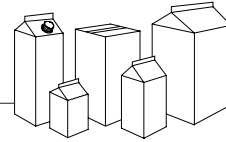

GABLE-TOP PACKAGING MACHINERY SYSTEMS



## NiMCO MODEL 210G

The NiMCO Model 210G is a single lane form / fill / seal machine for gable-top carton. Unique to this model is the full stainless steel frame design, and simplicity of the component technologies.



### Machine Operation

The NiMCO Model 210G is designed for the inline forming, filling and sealing of Gallon (4 liter) gable-top cartons. Utilizing state-of-the-art technology, this machine provides accurate product fills and dependable carton seals with output speeds up to 500 CPH. Other NiMCO models are available for filling 4 oz (120ml) to 5 liter volumes, with speeds up to 7500 CPH.

### Machine Features

- All mechanical drive system
- Satisfies sanitation requirements
- Stainless steel frame construction
- Variable speed index drive
- Low maintenance requirements
- Simple size changeover
- Compact machine dimensions
- Manufactured in USA.

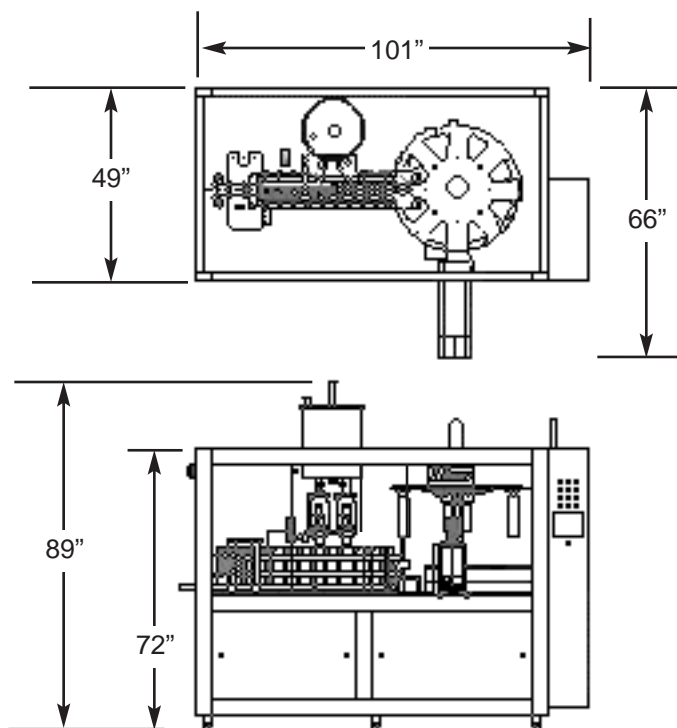

---

Container Volume	Machine Model	Production Speed
Gallon (4 Liter)	210G	up to 500 CPH

Production speeds are subject to carton and spout variations

---

**Utilities:** (220, 415, 440V available)

Electrical: 380V 3pH 50/60Hz  
 Peak: 28 KVA  
 Air: 85 psi / 5.8 bar  
 Peak: 11.3 scfm / 319 lpm  
 Water: 50F / 10C Max  
 Consumption: 2.0 gpm / 7.6 lpm

**Machine Weight:**

Machine (Net): 3700 lbs (1680kg)  
 Shipping Weight: 4400 lbs (1990kg)

**Accessories:**

- Spare Parts Kit
- Date Coding Units
- Level Controls / Alarms
- Automatic Greasing Systems
- Imperial Gallon / 5 Liter Tooling
- Auto Clean Systems
- Optional Filling Systems

*NiMCO reserves the right to change specifications without prior notice.*

*Utilities are accurate at time of printing and can vary at installation.*