

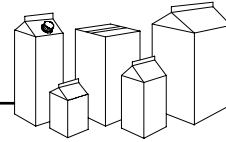

GABLE-TOP PACKAGING MACHINERY SYSTEMS



NIMCO MODEL 280QL

The NiMCO Model 280QL is a single lane form / fill / seal machine for gable-top carton. Unique to this model is the full stainless steel frame design, and simplicity of the component technologies.



Machine Operation

The NiMCO Model 280QL is designed for the inline forming, filling and sealing of half-pint (250ml) to quart (one liter) gable-top cartons. Utilizing state-of-the-art technology, this machine provides accurate product fills and dependable carton seals with output speeds up to 1500 CPH. Other NiMCO models are available for filling 4 oz (120ml) to 5 liter volumes, with speeds up to 7500 CPH.

Machine Features

- All mechanical drive system
- Satisfies sanitation requirements
- Stainless steel frame construction
- Variable speed index drive
- Low maintenance requirements
- Simple size changeover
- Compact machine dimensions
- Manufactured in USA.

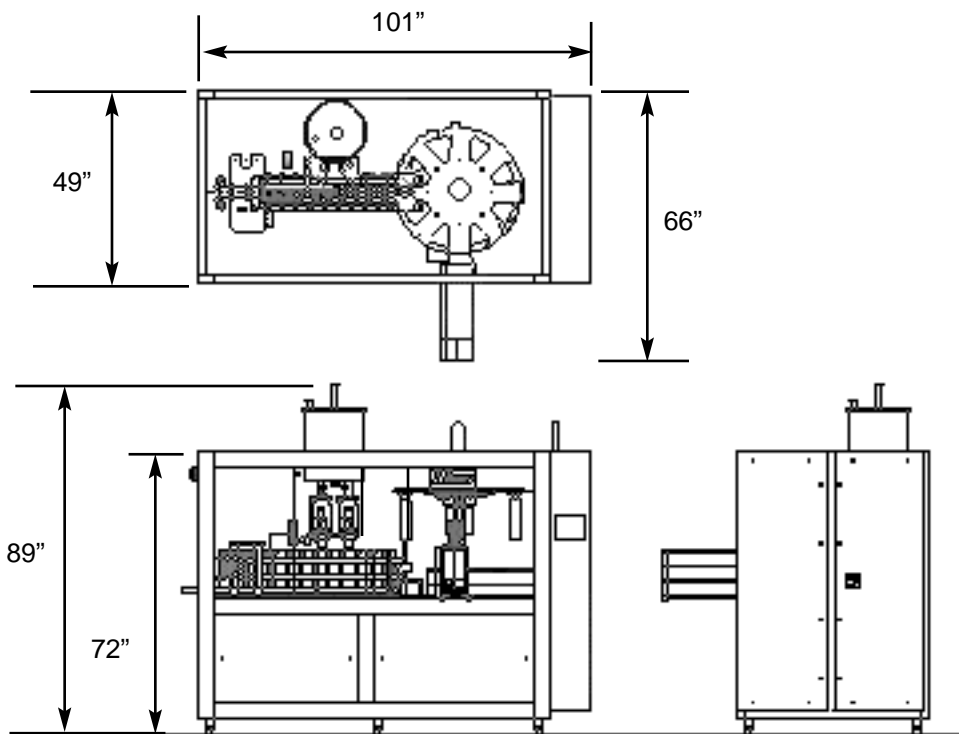

Container Volume	Machine Model	Production Speed
8, 16 oz (250, 500ml)	280QL	25 CPM / 1500 CPH
32 oz. (1 Liter)	280QL	20 CPM / 1200 CPH

Production speeds are subject to carton and spout variations

Utilities: (220, 415, 440V available)

Electrical: 380V 3pH 50/60Hz
 Consumption: 28 KVA
 Air: 85 psi / 5.8 bar
 Consumption: 11.3 scfm / 319 lpm
 Water: 50F / 10C Max
 Consumption: 2.0 gpm / 7.6 lpm

Accessories:

- Spare Parts Kits
- Date Coders
- Level Controls / Alarms
- Automatic Greasing Systems
- Auto Clean Systems
- Optional Filling Systems

Machine Weight:

Machine (Net): 3700 lbs (1680kg)
 Shipping Weight: 4400 lbs (1990kg)

NiMCO reserves the right to change specifications without prior notice.