

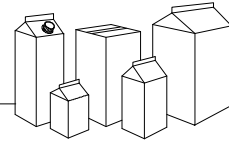

GABLE-TOP PACKAGING MACHINERY SYSTEMS



## NiMCO MODEL 580QL

NiMCO Model 580QL is a single lane, single index form, fill and seal machine for gable-top cartons. Unique to this model is the full stainless steel frame design, and simplicity of the component technologies.

The **new** CAP-PAC<sup>®</sup> Spout Applicator can be installed into this machine to automatically feed, apply and weld plastic spouts to gable-top containers. Fitments can be applied to standard liquid package cross-sections, from 8 oz (250ml) to one gallon (5 liter) in Tetra Rex<sup>®</sup> or Pure Pak<sup>®</sup> style constructions, custom package formats and rectangular shapes.



### Machine Operation

The NiMCO Model 580QL is designed for the inline forming, filling and sealing of 250-500 ml at 50 CPM (3000 CPH) and 1 liter at 40 CPM (2400 CPH) of PE coated gable-top cartons. Utilizing state-of-the-art technology, this machine provides accurate product fills and dependable carton seals.

Other NiMCO models are available for filling 4 oz (120ml) to 5 liter volumes, with speeds up to 7500 CPH.

### Machine Features

- Mechanical drive system
- Heavy duty stainless steel frame
- Indexing electric heaters
- PLC control systems
- Variable frequency drive
- Low maintenance requirements
- Simple size changeover
- 46 ft<sup>2</sup> floor space requirement
- Optional NiMCO Spout Applicator<sup>®</sup>

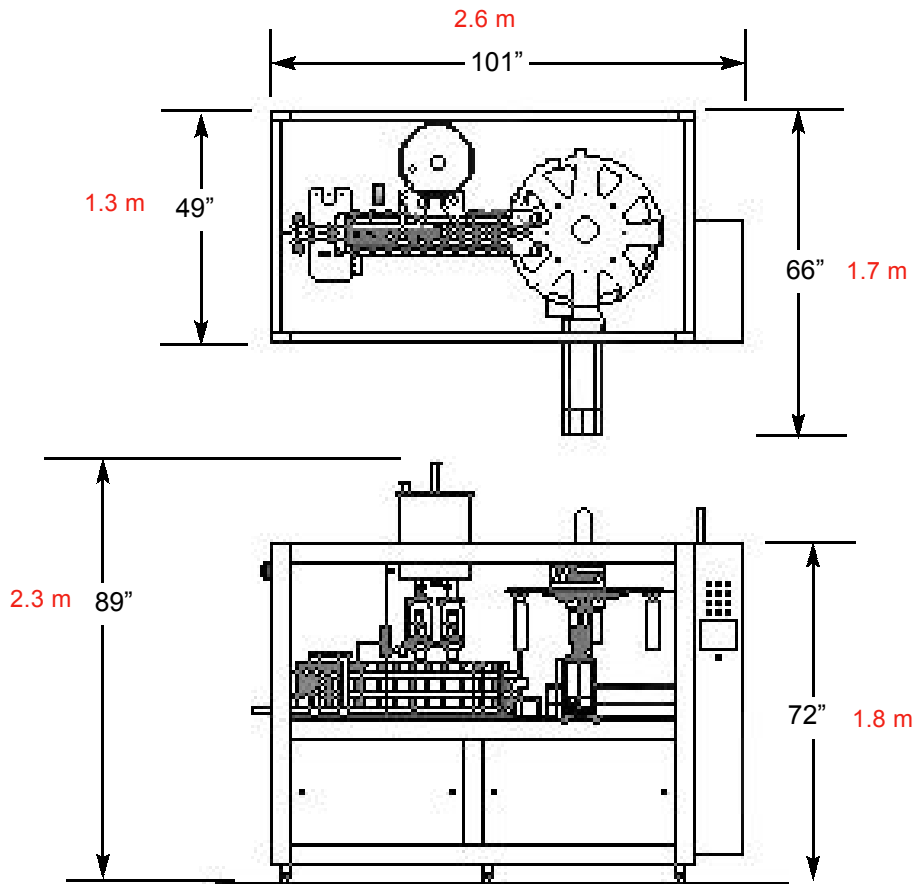

Container Volume	Machine Model	Production Speed
8, 16 oz (250, 500ml)	580QL	50 CPM / 3000 CPH
32 oz. (1 Liter)	580QL	40 CPM / 2400 CPH

Production speeds are subject to variations in both product and cartons

**Utilities:** (220, 415, 440V available)

Electrical: 380V 3pH 50/ 60Hz  
 Consumption: 27 KVA  
 Air: 85 psi / 5.8 bar  
 Consumption: 4.0 scfm / 113 lpm  
 Water: 50° F / 10° C Max  
 Consumption: 2.0 gpm / 7.6 lpm

**Machine Weight:**

Machine (Net): 4600 lbs (2080 kg)  
 Shipping Weight: 5400 lbs (2440 kg)

*Specifications are correct at time of printing*

**Available Accessories:**

- Color Touch Screen Control Panel
- Spare Parts Kit
- Date Coding Unit
- Level Controls / Alarms
- Automatic Greasing System
- Auto Clean System
- HEPA Air Filter Unit
- Machine Sanitizing
- Carton Sterilization Systems
- CAP-PAC® Spout Applicator
- Auxiliary Filling Systems
- Dry Fill Capabilities

*Due to continuing improvements NIMCO reserves the right to change or modify specifications without notice.*