

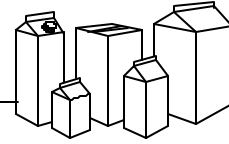

GABLE-TOP PACKAGING MACHINERY SYSTEMS



## NiMCO MODEL 680QL

NiMCO Model 680QL is a single lane, single index form, fill and seal machine for gable-top cartons. Unique to this model are the compact frame design and simplicity of the component technologies.

The **new** CAP-PAC<sup>®</sup> Spout Applicator can be installed into this machine to automatically feed, apply and weld plastic spouts to gable-top containers. Fitments can be applied to standard liquid package cross-sections from 8 oz (250ml) to one gallon (5 liter) in Tetra Rex<sup>®</sup> or Pure Pak<sup>®</sup> style constructions, custom package formats and rectangular shapes.



### Machine Operation

The NiMCO Model 680QL is designed for the inline forming, filling and sealing of half-pint (250ml) to quart (one liter) gable-top cartons. Utilizing state-of-the-art technology, this machine provides accurate product fills and dependable carton seals, with speeds up to 3000 CPH. Application of spouts from the inside of the container is available with the NiMCO CAP-PAC<sup>®</sup> Spout Applicator System. Other machine models are available for 1.5, 2, 4 and 5 liter carton volumes.

### Machine Features

- Mechanical Drive System
- Heavy Duty Stainless Steel Frame
- PLC Control System
- Indexing Electric Heaters
- Variable Frequency Drive
- Simple Size Changeover
- Compact Machine Dimensions
- Optional NiMCO Spout Applicator<sup>®</sup>

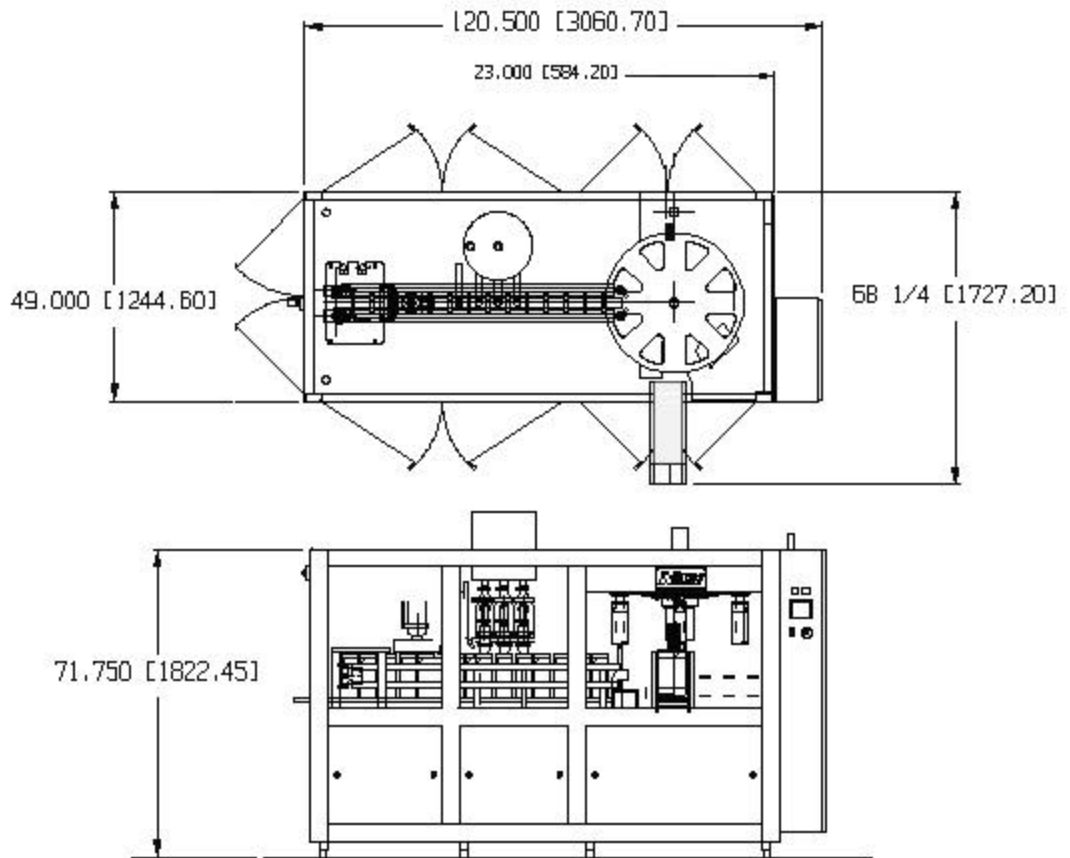

Container Volume	Machine Model	Production Speed
8, 16, 32 oz (250, 500, 1000ml)	680QL	50 CPM / 3000 CPH
	680QL CAP-PAC®	45 CPM / 2700 CPH

Production speeds are subject to variations in carton and product

**Utilities:** (220, 415, 440V available)

Electrical: 380V 3pH 50Hz  
 Consumption: 28 KVA  
 Air: 85 psi / 5.8 bar  
 Consumption: 10.0 scfm / 283 lpm  
 Water: 50F / 10C Max  
 Consumption: 2.0 gpm / 7.6 lpm

**Machine Weight:**

Machine (Net): 6100 lbs (2775 kg)  
 Shipping Weight: 7000 lbs (3180 kg)

**Shipping Dimensions:**

80" W x 138"L x 84"H • Inches  
 2.1W x 3.5L x 2.25H • Meters

**Accessories:**

- Spare Parts Kits
- Date Coding Units
- Level Controls / Alarms
- Automatic Greasing System
- Auto Clean Systems
- Touch Screen Controls
- Carton Sterilization Systems
- CAP-PAC® Spout Applicator
- Optional Filling Systems

*Due to continuing improvements, NIMCO reserves the right to change specifications and options without prior notice. Utility requirements are accurate at time of printing and may vary according to individual installation.*